

### ALI4-Model CE

- Permanent magnet motor CE
- Three phase or single phase motor CE
- Worm gearbox
- Acme lead screw or ballscrew (VRS)
- Chrome plated steel push rod
- Life long grease lubricated
- IP65, tested according to rule CEI EN 60529  
D.C. motor IP 54 standard - IP65 on request
- NB: Only for brake motors Standard IP54, IP65 on request
- Working temperature range -10°C +60°C
- Intermittent duty S3 30% (5 min) a +30°C\*
- Limit switches, potentiometer and encoder on request

(\* ) For any special duty please contact our technical dept.

ALI4 (Vac 3-phase)					
Fmax (N)	Speed (mm/s)	Version	Motor size	Motor power (KW)	Motor speed (rpm)
* 2100	93	M01	IEC71	0,55	2800
* 3900	47	M02	IEC71	0,55	2800
5300	23	M03	IEC63	0,37	1400
8600	9	M04	IEC63	0,22	1400
9400	6	M05	IEC63	0,18	1400
10000	3	M06	IEC63	0,13	1400
10000	2	M07	IEC56	0,09	1400

ALI4 (Vdc)						
Fmax (N)	Speed (mm/s)	Version	Motor size	Motor power (KW)	Motor speed (rpm)	Max Current for Fmax(A) 24Vdc
* 600	100	M20	D.85	-	3000	10
* 1100	50	M21	D.85	-	3000	13
2800	20	M22	D.85	-	3000	13,5
4100	13	M23	D.85	-	3000	14
6800	7	M24	D.85	-	3000	12
10000	4	M25	D.85	-	3000	13

ALI4-VRS (ballscrew 16x5) (Vac)					
Fmax (N)	Speed (mm/s)	Version	Motor size	Motor power (KW)	Motor speed (rpm)
* 2500	58	M08	IEC63	0,25	2800
3100	29	M09	IEC63	0,18	1400
3400	23	M10	IEC56	0,14	2800
5000	15	M11	IEC56	0,14	2800
6000	7	M12	IEC56	0,09	1400
7500	4	M13	IEC56	0,09	1400

ALI4 - VRS (ballscrew 16x5) 24 Vdc						
Fmax (N)	Speed (mm/s)	Version	Motor size	Motor power (KW)	Motor speed (rpm)	Max Current for Fmax(A) 24Vdc
* 2400	63	M26	D.85	-	3000	14
3400	25	M27	D.85	-	3000	12
3900	16	M28	D.85	-	3000	10
6800	8	M29	D.85	-	3000	9
7500	5	M30	D.85	-	3000	9

With single-phase motors type M (see motor choice guideline in paragraph ACCESSORIES) performances are 20% lower than the three-phase motor.

\* When speed is more than 40 mm/s and/or strokes longer than 350mm, check STROKE SETUP section; BRAKEMOTOR IS RECOMMENDED

\*\* For 12 Vdc power supply currents are doubled and loads are 20% lower.

BEFORE OPERATING ACTUATOR MAKE SURE YOU READ AND UNDERSTOOD BASIC OPERATIONAL INSTRUCTIONS SHOWN ON USERMANUALS, AVAILABLE FROM WEBSITE.

THIS DOCUMENT DISPLAYS MOST TYPICAL STANDARD FEATURES AND SETUPS: CONTACT OUR OFFICES FOR MORE.

ACTUATOR SHALL NOT COME TO **MECHANICAL STROKE-END**, TO AVOID **FAILURES**.

CONSIDER MECVEL's LIMITSWITCHES ( MODEL ALI4-F or ALI4-FCM) OR PUT THEM ON MACHINE/FRAME.



MecVel reserves the right to change products information and/or features without notice; all data contained in this catalogue are purely indicative and not binding for the company.

### ALI4 Version without limitswitches

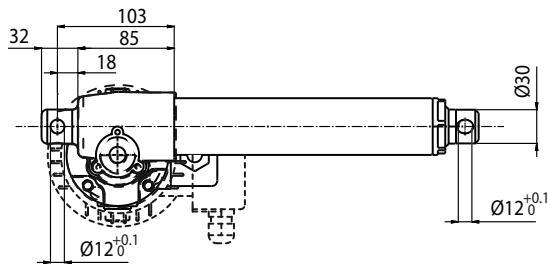
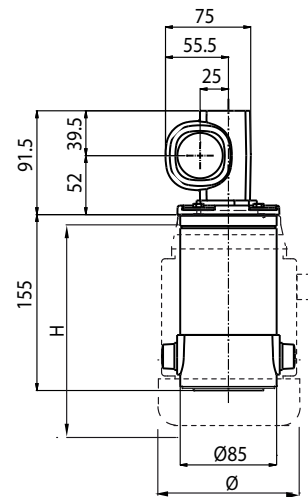
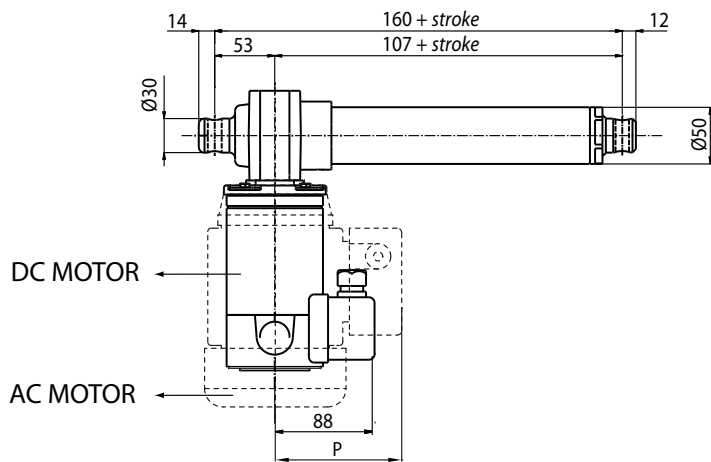

A.C. MOTORS DIMENSIONS				
GR. / SIZE	TYPE	H	Ø	P
56	Standard	168	116	108
	Brake motors	200		
63	Standard	190	129	110
	Brake motors	235		
71	Standard	220	146	121
	Brake motors	267		

With safety nut "G" = + 30 mm  
 ALI4-VRS = + 25 mm ( safety nut unavailable)  
 Bellows + 20mm (for FCM limitswitches contact our Offices)

### ALI4-F Version with limitswitches

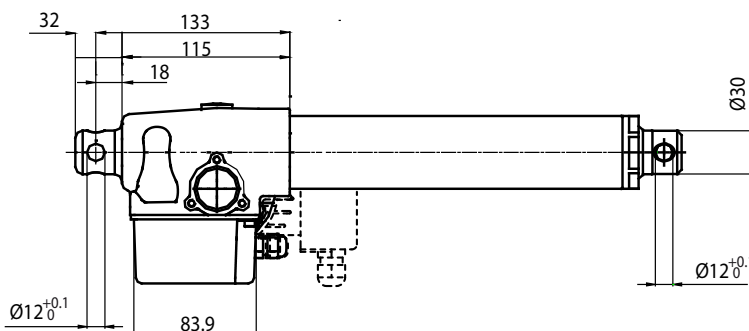
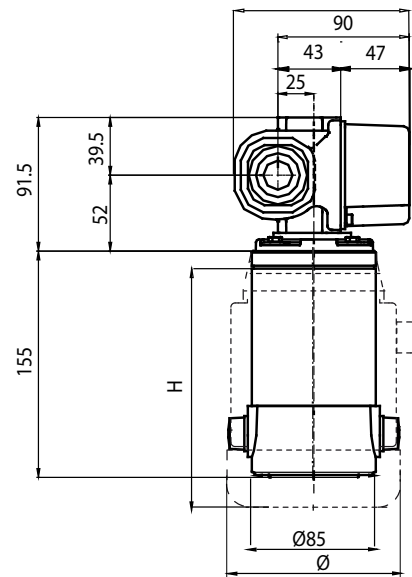
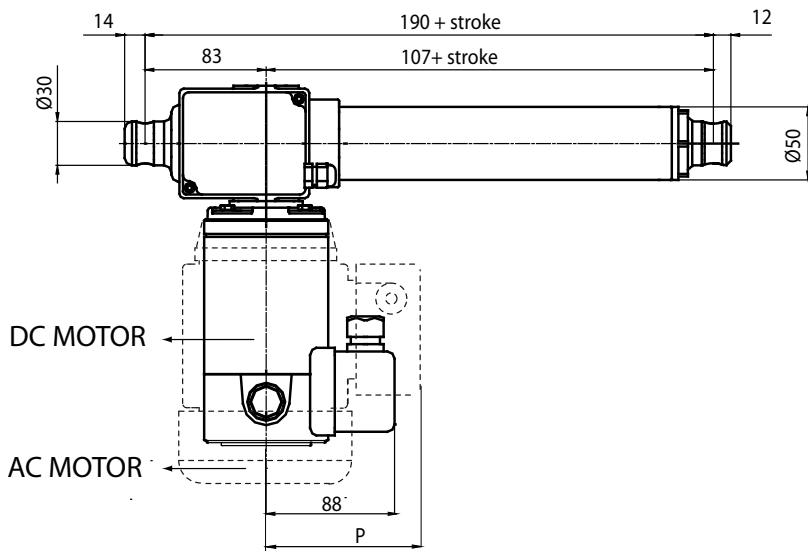

A.C. MOTORS DIMENSIONS				
SIZE	TYPE	H	Ø	P
56	Standard	168	116	108
	Brake motors	200		
63	Standard	190	129	110
	Brake motors	235		
71	Standard	220	146	121
	Brake motors	267		

With safety nut "G" = + 30 mm  
 ALI4-VRS = + 25 mm ( safety nut unavailable)  
 Bellows + 20mm (for FCM limitswitches contact our Offices)

### REAR ENDS

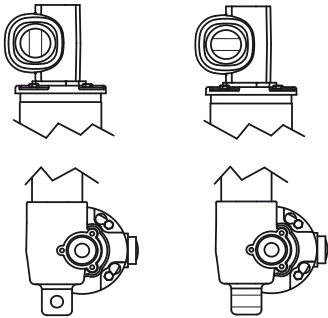

P1 Standard

P2 Rotated 90°

### MOTOR POSITION

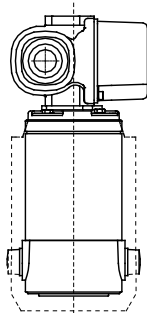

M0 ( Standard)

### E-BOX POSITION

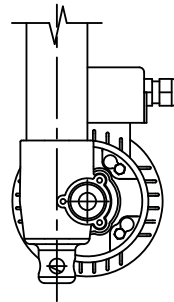

1 Standard

### LIMIT SWITCHES POSITION

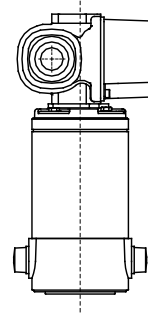

FC1 (Standard) M0

**STROKE SETUP:** Useful tips for handling stroke and avoid run-on-block collision.

When stroke is more than 350 mm, add 50 mm extra-stroke as guidance, and put corresponding value in ordering-key.

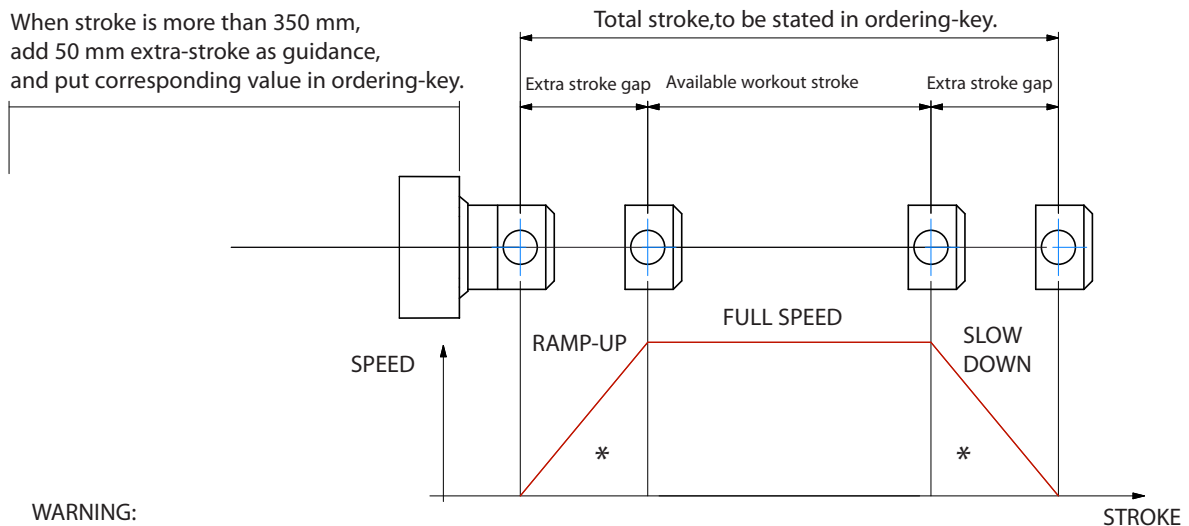

**WARNING:**  
 SPEED-TIMING ALONG STROKELENGTH:  
 ramps are extremely important when speed is > 40mm/s !!! Inverter or PWM drive recommended!  
 \* The more speed raises the more extra stroke has to raise too.

**BUCKLING:** With strokes longer than 500mm, BUCKLING can be a risk: please check mounting with our offices and/or see user manuals.

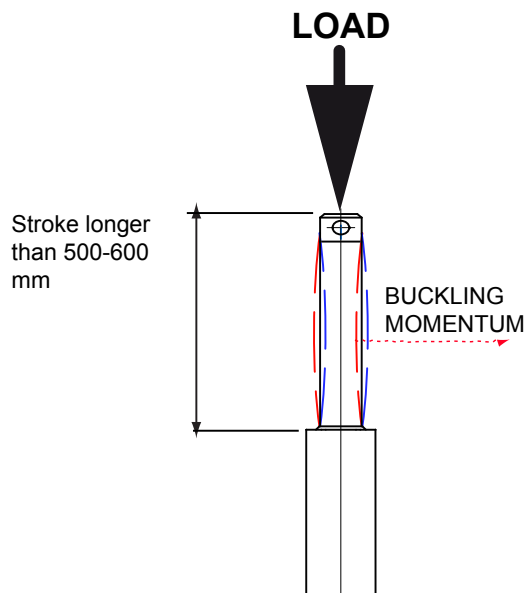

**IMPORTANT:**  
 Long strokes, even if load is low, can generate significant buckling momentums, as sketch slows.  
 This happens when actuator is in its all-opened position: that's the reason why we recommend 100 mm extra-stroke.  
 Pushtube will have this 100 mm-portion always inside the overtube, improving guidance against buckling.  
 For more information on this, contact our office.

### ORDERING KEY

ALI4 / 0250 / M01 / CA-400/50-T-56-4-0,09 / AB / FC1 / M0 / 1 / E01 / 2FC2 / POT01A / P1 / A1

**MODEL:** \_\_\_\_\_  
 ALI4 / ALI4-F / ALI4-FCM / ALI4-FCI  
 ALI4-VRS / ALI4-VRS-F / ALI4-VRS-FCM  
 ALI4-VRS-FCI

**STROKE:** \_\_\_\_\_  
 es. 250 mm = 0250

**VERSION:** (Pag. 37) \_\_\_\_\_  
 Advise: choose among  
 M00 Not standard speed  
 Flanged Version = Rpm  
 Advise reduction ratio and screw pitch

**MOTOR:** \_\_\_\_\_  
 Advise only if with motor:  
**A.C.:** version, voltage, type, size, n°pole, power  
**D.C.:** version, voltage, size, Rpm  
 With motorflange only put 0  
 With special motorflange put: PD

**AC MOTOR OPTIONS:** (Pag. ACCESSORIES) \_\_\_\_\_  
 Motorflange: for motorflange version only advise size - i.e. for IEC56 B14 put 56B14  
 No motor or DC motor: leave all following parameters blank  
 Protection Degree: IP65, for selfbrake motor IP54 standard  
 Brake type: for brakemotors only: ES, FECA  
 Options: Advise if needed (ES, AB 2'shaft)

**LIMIT SWITCHES POSITION:** \_\_\_\_\_  
**FC1** None: Leave blank

**MOTOR POSITION:** \_\_\_\_\_  
**M0** None: Leave blank

**E-BOX POSITION:** \_\_\_\_\_  
**1** No Motor: Leave blank

**ENCODER:** (Pag. ACCESSORIES) \_\_\_\_\_  
 None: Leave blank

**LIMIT SWITCHES:** (Pag. ACCESSORIES) \_\_\_\_\_  
 None: Leave blank

**POTENTIOMETER:** (Pag. ACCESSORIES) \_\_\_\_\_  
**POT01A** (1Kohm) **POT10A** (10Kohm) None: Leave blank

**REAR END:** \_\_\_\_\_  
**P1** = Eyelet (standard) **P2** = Eyelet (90°)

**FRONT END:** \_\_\_\_\_  
**A1** = Eyelet (Std pag.38) **A3** = Yoke + Clip  
**A4** = Rod end **A7** = M12 male

**NOTE: COMPLETE THE ORDERING KEY ADDING THE OPTIONS YOU CAN FIND IN THE "ACCESSORIES AND OPTIONS" SECTION.**

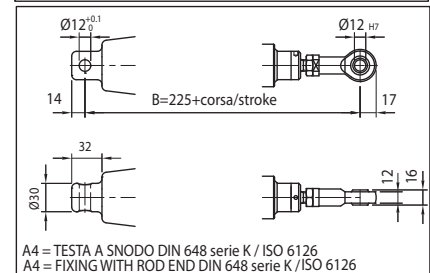
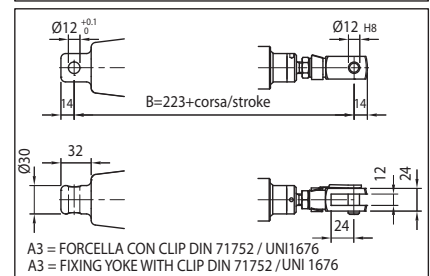
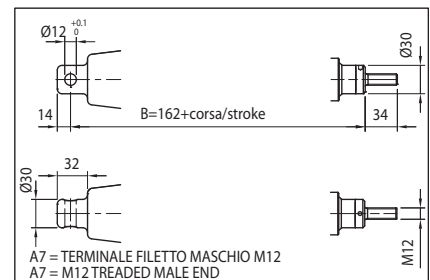
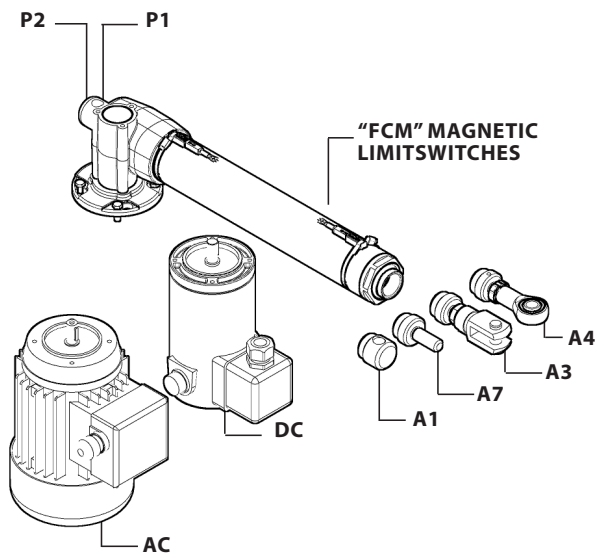

**Note: "B" dimension variations depending on model**

- |  |  |                                |                      |
|--|--|--------------------------------|----------------------|
| ALI4 = see pictures                    | ALI4-F = + 30 mm                       | ALI4-FCM = + 42,5 mm           | ALI4-FCI = + 42,5 mm |
|  | with safety nut "G" = + 30 mm          | (i.e. ALI4-F "G" option = +30) |                      |
| ALI4-VRS (versione 16x5) = + 25 mm     | ALI4-VRS-F (versione 16x5) = + 55 mm   |                                |                      |
| ALI4-VRS-FCM (versione 16x5) = + 53 mm | ALI4-VRS-FCI (versione 16x5) = + 53 mm |                                |                      |
| L = + 15 mm                            |  |                                |                      |

Bellows = + 15 mm (excluding FCM and FCI version, for versions FCM and FCI contact MecVel)