

ALI1 Model CE

- Permanent magnet motor 12 - 24 Vdc
- Double worm gearbox
- ACME lead screw
- Aluminum push rod (Stainless steel on request)
- Permanent grease lubrication
- IP 65, tested according to rule CEI EN 60529
- Working temperature range -10°C +60°C
- Intermittent duty S3 30% (5 min) a 30°C*
- Encoder on request
- Limit switches on request (ALI1-PF)

(*) For any special duty please contact our technical dept.



ALI1 (Vdc)						
Fmax (N)	Speed (mm/s)	Version	Motor size	Motor power (KW)	Motor speed (rpm)	Max Current for Fmax(A) 24Vdc
* 95	90	M12	40S	-	6300	2,8
* 190	90	M13	40L	-	6000	4,5
* 130	60	M10	40S	-	6300	3,1
* 270	60	M11	40L	-	6000	6
* 200	45	M07	40S	-	6300	2,6
* 400	45	M09	40L	-	6000	3,1
290	30	M04	40S	-	6300	2,8
580	30	M06	40L	-	6000	4,5
500	15	M01	40S	-	6300	2,7
1200	15	M03	40L	-	6000	5

**

* When speed is more than 30 mm/s and/or strokes longer than 200 mm, check STROKE SETUP section.

** For 12 Vdc power supply currents are doubled and loads are 20% lower.

BEFORE OPERATING ACTUATOR MAKE SURE YOU READ AND UNDERSTOOD BASIC OPERATIONAL INSTRUCTIONS SHOWN ON USERMANUALS, AVAILABLE FROM WEBSITE.

THIS DOCUMENT DISPLAYS MOST TYPICAL STANDARD FEATURES AND SETUPS: CONTACT OUR OFFICES FOR MORE.

ACTUATOR SHALL NOT COME TO **MECHANICAL STROKE-END**, TO **AVOID FAILURES**.

CONSIDER MECVEL'S LIMITSWITCHES (MODEL ALI1-F) OR PUT THEM ON MACHINE/FRAME.



MecVel reserves the right to change products information and/or features without notice; all data contained in this catalogue are purely indicative and not binding for the company.

ALI1

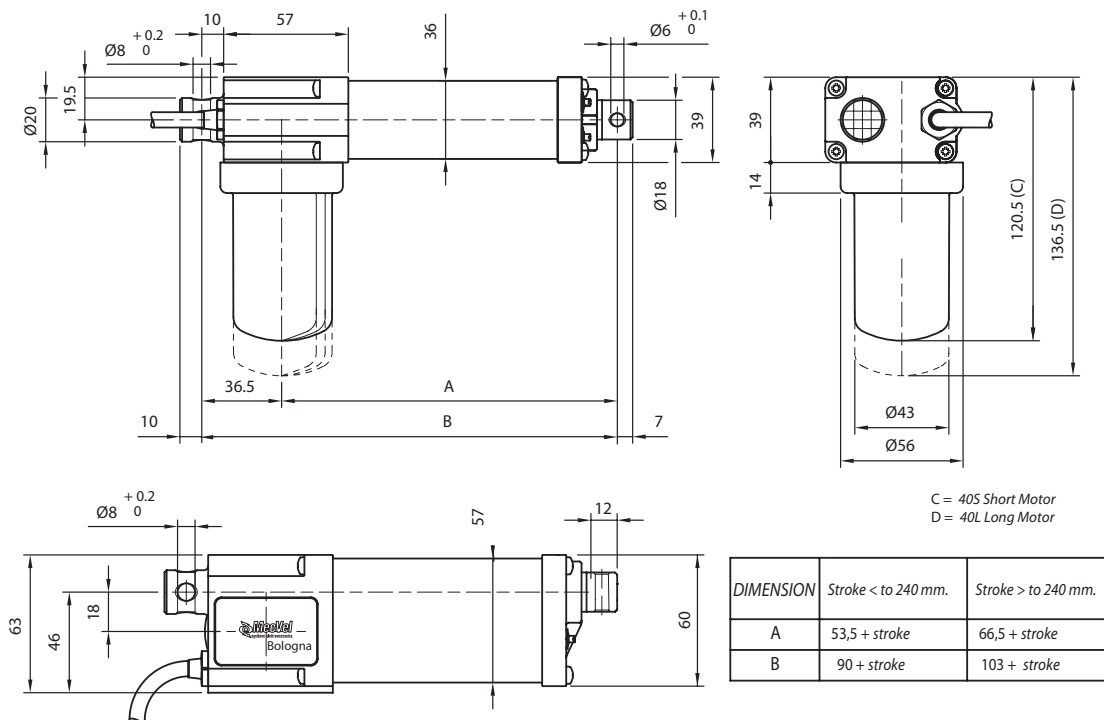

ELECTRICAL WIRINGS

Options available:

- C01/C08 = motor
- C02/C09 = N° 2 microswitches, diode-wired
- C03/C10 = motor + N° 2 micro
- C04/C11 = motor + N° 3 micro
- C05/C12 = motor + encoder
- C06/C13 = N° 2 micro diode wired + encoder
- C07/C14 = motor + N° 2 micro + encoder
- C00 = special wiring (Presence of not standard options)

WARNING:

Micros are actuated by a cam lying on push-rod itself. Micro signal, for speeds higher than 30 mm/s, needs to be handled in its very impulse (I.E. when actuated) and not in its state.

Alternatively, MecVel can add a bush to keep the microswitch lever pressed for a longer time avoiding switch signal mistakes, but cause loss of 10 mm of stroke.

Connections C02 and C06 make a circuit which stops motor supply, so that the push rod won't overstep the area of the two micros.

This system can work only if inertia generated by the actuator and load connected to it does not allow to over-step the micro when stroke is over.

So, this works just with low speeds (M01 - M03), with a load opposing the ongoing direction of the push rod. If not, relay or PLC solutions, using C03 and C07 connections, are needed..Wiring diagrams of connections above are following:

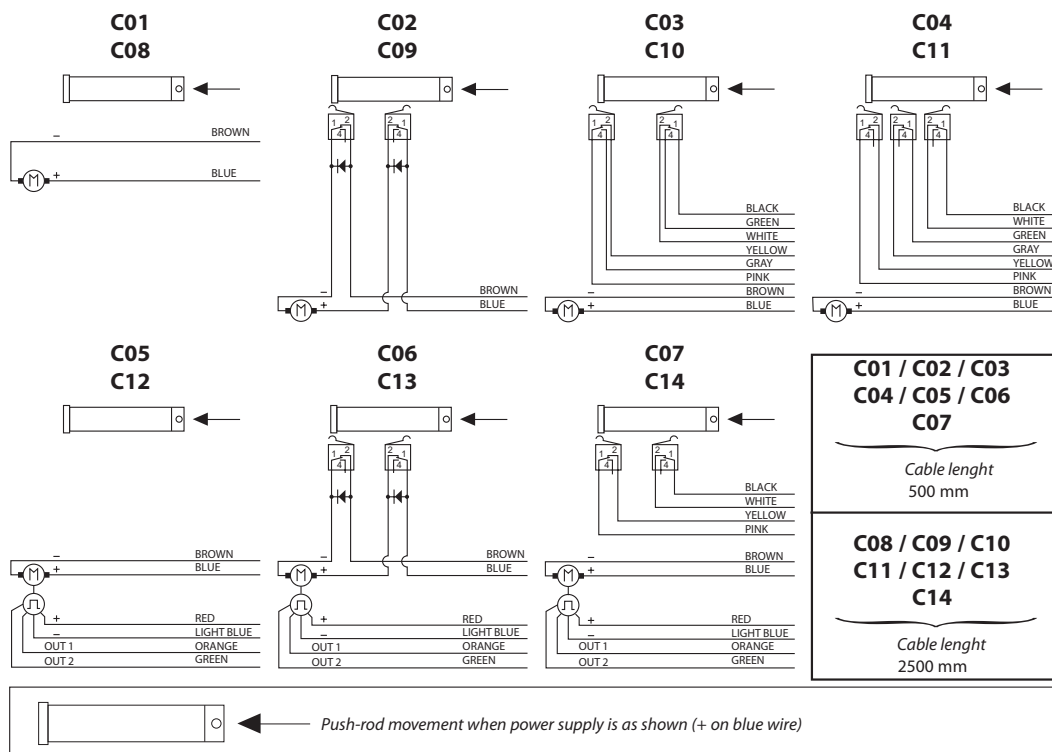

MOTOR POSITION

Motor can be installed on both sides of the actuator, thus achieving two versions, as show below. Actuator is seen from backwards.

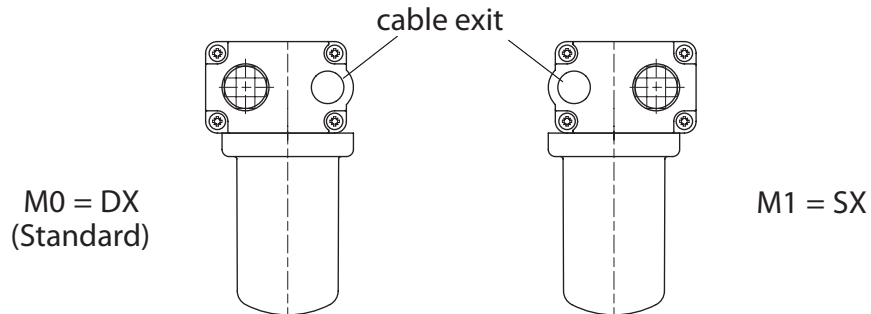

STROKE SETUP: Useful tips for handling stroke and avoid run-on-block collision.

When stroke is more than 350 mm, add 50 mm extra-stroke as guidance, and put corresponding value in ordering-key.

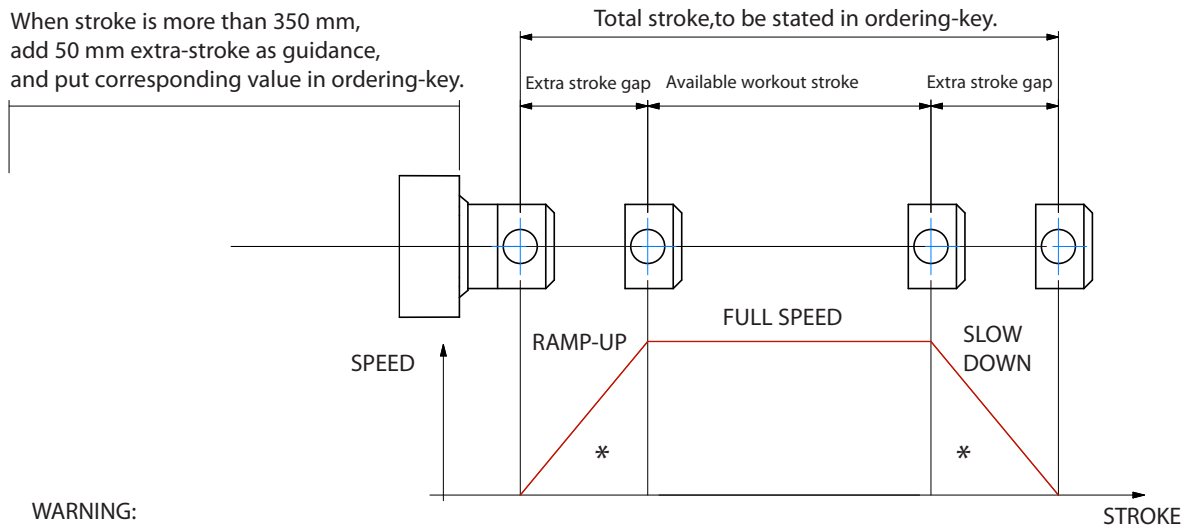

WARNING:
SPEED-TIMING ALONG STROKELENGTH:
 ramps are extremely important when speed is >30 mm/s!!! Inverter or PWM drive recommended!
 * The more speed raises the more extra stroke has to raise too.

BUCKLING: When stroke is longer than 300mm, BUCKLING can be a risk: please check mounting with our offices and/or see user-manuals.

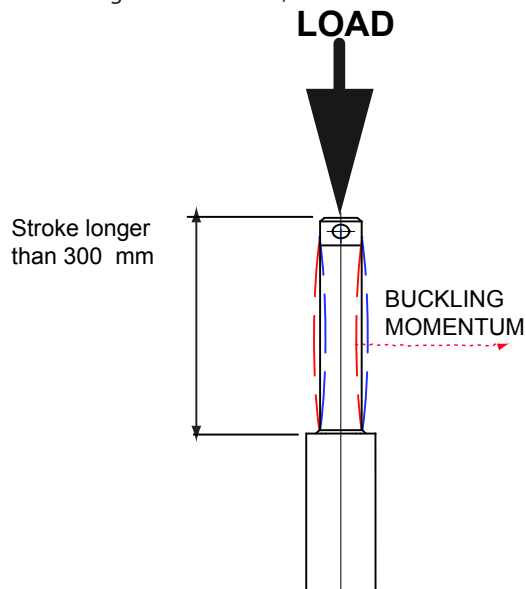

IMPORTANT:
 Long strokes, even if load is low, can generate significant buckling momentums, as sketch slows.
 This happens when actuator is in its all-opened position: that's the reason why we recommend 100 mm extra-stroke.
 Pushtube will have this 100 mm-portion always inside the overtube, improving guidance against buckling.
 For more information on this, contact our office.

ORDERING KEY

ALI1F / 0250 / M01 / 12 / M0 / C02 / P1 / A2

MODEL: _____

ALI1 ALI1-F

STROKE: _____

es. 250 mm = 0250

VERSION: _____

M01 / M03 / M04 / M06 / M07 / M09 / M10 / M11 / M12 / M13

M00 = Not standard speed

MOTOR: (available) _____

12 = 12 Vdc

24 = 24 Vdc

MOTOR POSITION: _____

M0 / M1

MOTOR OPTIONS: _____

C01 / C08: Motor

C02 / C09: 2LS Diode wired

C03 / C10: Motor + 2LS

C04 / C11: Motor + 3LS

C05 / C12: Motor + encoder

C06 / C13: 2LS diode wired + encoder

C07 / C14: Motor + encoder + 2LS

C00: Special wiring (Presence of not standard options)

Note: LS (limit switches)

REAR END: _____

P0 = None P1/P2 = standard

FRONT END: _____

A2 = Yoke (Std pag.14)

A3 = Yoke + Clip

A4 = Rod end

A7 = M8x20 male

NOTE: COMPLETE THE ORDERING KEY ADDING THE OPTIONS YOU CAN FIND IN THE "ACCESSORIES AND OPTIONS" SECTION

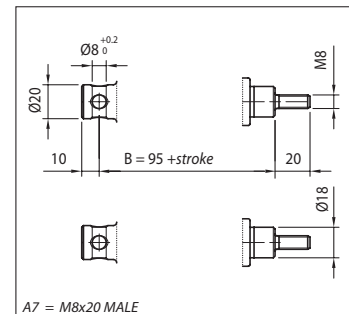
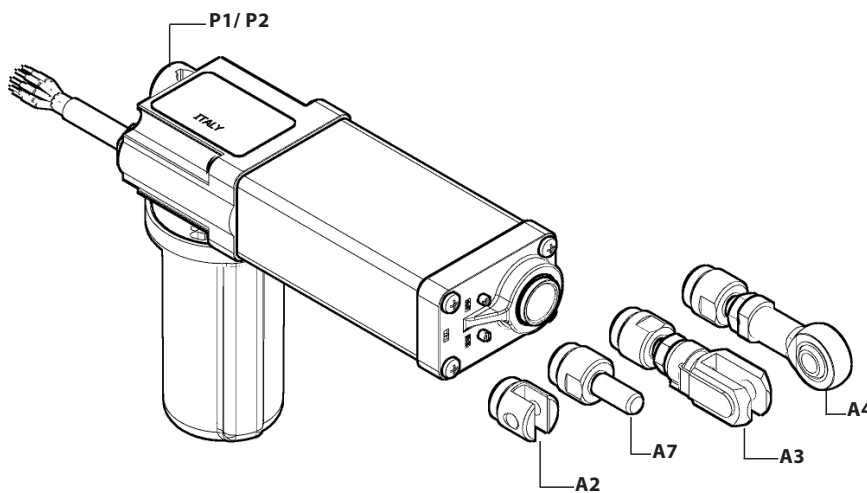

A7 = M8x20 MALE

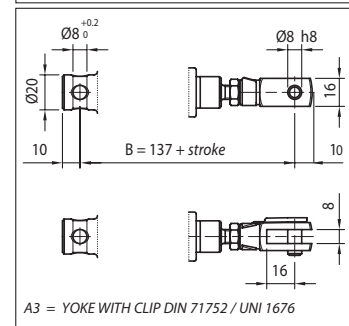

A3 = YOKE WITH CLIP DIN 71752 / UNI 1676

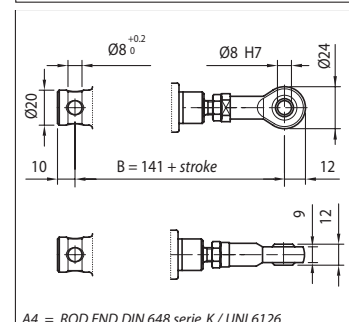

A4 = ROD END DIN 648 serie K / UNI 6126

Note: "B" dimension changes according to model

ALI1-F = See pictures

ALI1-F stroke > 240 mm = + 13 mm